

PYRAMID[®]
Gold Series
OWNER'S
MANUAL

PROFESSIONAL P. A. AMPLIFIER

MODEL : PA-305

INTRODUCTION

Thank you for purchasing PYRAMID the MODEL PA-305 P. A. AMPLIFIER. The unit has been designed using the latest electronic technology available. The unit will offer exceptional performance and reliability at an affordable price. The unit delivers 100 watts of power and features 4 microphone input jacks, 70-volt line output, CD/AUX input jacks, selectable speaker impedance (4Ω, 8Ω, 16Ω, 70V) output, five individual source mixing controls, master volume control, feedback filter and monitor jack-etc.

In order to obtain the maximum performance from the unit, be sure to read this manual carefully.

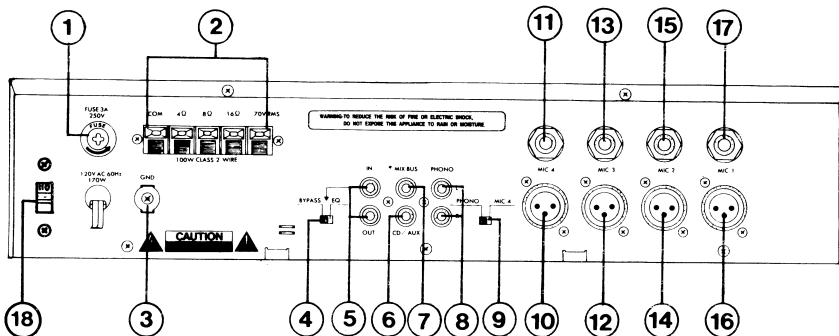
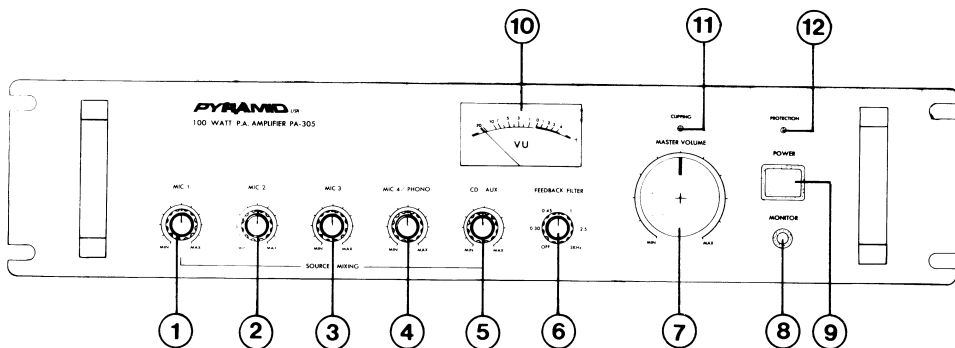

FEATURES

A. FRONT PANEL

1. MIC 1 VOLUME CONTROL

To adjust MIC1 volume control to the desired volume and balance. Volume is increased when turning the controls clockwise.

2. MIC 2 VOLUME CONTROL

Same as item 1 to adjust MIC 2.

3. MIC 3 VOLUME CONTROL

Same as item 1 to adjust MIC 3.

4. MIC 4/PHONO VOLUME CONTROL

Same as item 1 to adjust MIC 4/PHONO.

5. CD/AUX VOLUME CONTROL

Same as item 1 to adjust CD/AUX.

6. FEEDBACK FILTER CONTROL

After you adjust the MASTER VOLUME and MIC 1, MIC 2, MIC 3, MIC 4/PHONO, CD/AUX controls, test the amplifier. If you hear any feedback, turn FEEDBACK FILTER clockwise until you reduce or eliminate the feedback.

7. MASTER VOLUME CONTROL

Volume is increased when turning the controls clockwise.

Care should be taken not to overdrive the amplifier once it reaches its maximum stage. This is indicated by LED CLIPPING indicator.

8. MONITOR JACK

To monitor the sound source, plug in your headphones to check and adjust the sound sources' balance.

9. POWER ON/OFF SWITCH

To power-up the amplifier, press the power switch to the on position.

10. POWER METER INDICATOR

Indicates the power level. These meters are illuminated for easy viewing in dark illuminations.

11. CLIPPING INDICATOR LED

The CLIPPING indicator lights when the unit maximum power output signal is exceeded. If this happens, reduce the MASTER volume or the level of the appropriate mixing control until the indicator flickers on sound level peaks.

12. PROTECTION INDICATOR LED

The indicator will light on, if the unit gets too hot because of a power overload. If this happens, press POWER to the off position to turn off the amplifier. Then let the unit cool and correct whatever caused the overload, press in POWER to turn the power back on.

B. REAR PANEL

1. POWER FUSE

This fuse is the power supply fuse. It protects the amplifier from unwanted voltage surges and the other abnormal operating conditions.

2. SPEAKER TERMINALS

Connect your speaker system to these terminals. You can connect one or more 4-, 8- or 16-ohm speakers to the amplifier, with or without transformers. To ensure equal volume from each speaker, all the connected speakers should have the same impedance rating.

3. GND SCREW TERMINAL

This is an alternate ground to earth point. Should you experience excessive noise attach a wire to this screw and attach the opposite end to a good ground connection. This ground point may also be used to eliminate when the amplifier is used with another unit as a mixer, turntable, etc.

4. BYPASS/EQ SWITCH

Sets the switch to the EQ position, you can connect an equalizer.

Sets the switch to the BYPASS position, the equalizer has no effect on your system's sound.

5. EQ IN/OUT RCA JACKS

To connect an equalizer to these jacks, you can have the effect on your system's sound.

6. CD/AUX INPUT JACK

To connect any high-level sound source, such as a CD player, tape deck, or tuner, to the amplifier's CD/AUX jack.

7. MIX BUS INPUT JACK

You can connect another PA-305 to this jack to double the size of your P.A. system, then you can use eight microphones and two auxiliary sound sources.

8. PHONO INPUT JACKS

To connect a low level audio input source (such as a magnetic cartridge turntable) to the amplifier's L and R PHONO jacks.

To avoid a low frequency hum, connect your turntables ground wire to the amplifier's GND screw.

9. PHONO/MIC 4 SWITCH

If you connect a low level audio input source to the PHONO jacks, set PHONO /MIC 4 to the PHONO position.

If you set PHONO/MIC 4 to the MIC 4 position, you can use MIC 4.

10. **MIC 4 XLR JACK**

To connect an XLR microphone to the jack.

11. **MIC 4 ¼ INCH JACK**

To connect a ¼ inch microphone to the jack.

12. **MIC 3 XLR JACK**

Same as item 10.

13. **MIC 3 ¼ INCH JACK**

Same as item 11.

14. **MIC 2 XLR JACK**

Same as item 10.

15. **MIC 2 ¼ INCH JACK**

Same as item 11.

16. **MIC 1 XLR JACK**

Same as item 10.

17. **MIC 1 ¼ INCH JACK**

Same as item 11.

18. **VOLTAGE SWITCH**

The PA-305 has selectable input voltage from 115V/60Hz which is the standard in the USA and Canada. You can also switch the input voltage to 230V/50Hz for European operation. Please make sure the switch is in the proper position before operating otherwise severe damage will result not covered by the warranty.

CONNECTION

A. CONNECTING INPUT SOURCES

1. Connecting Microphones

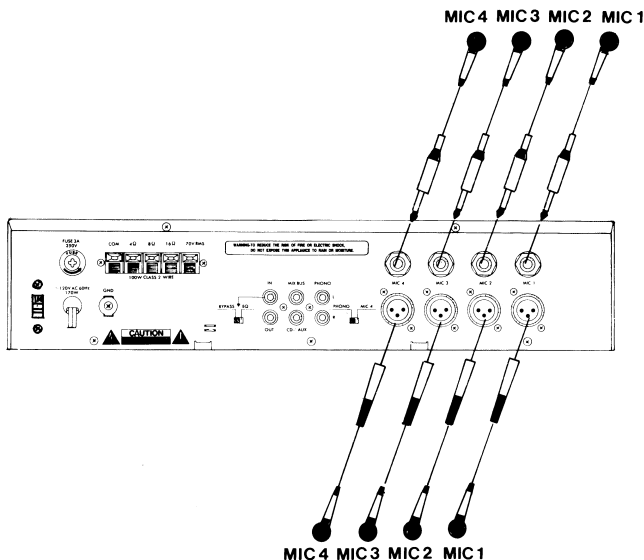

2. Connecting a Turntable

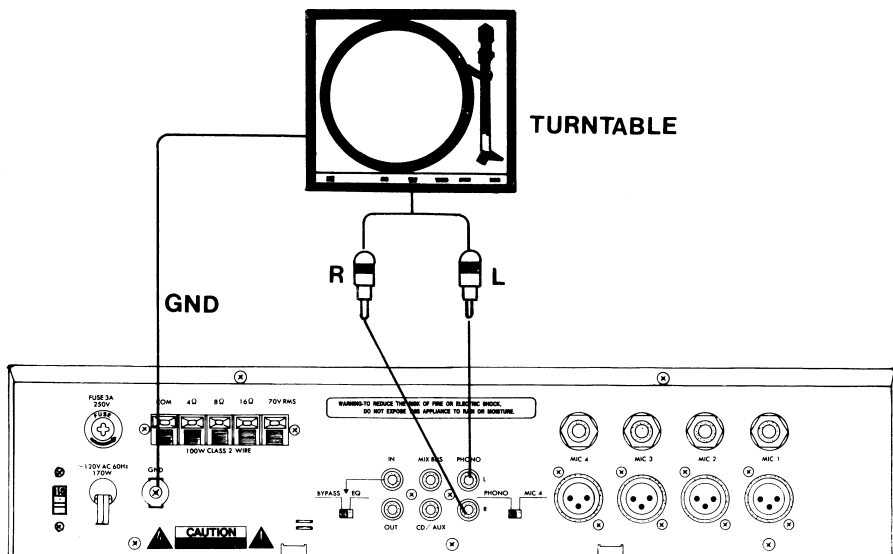

3. Connecting an Auxiliary Sound Source.

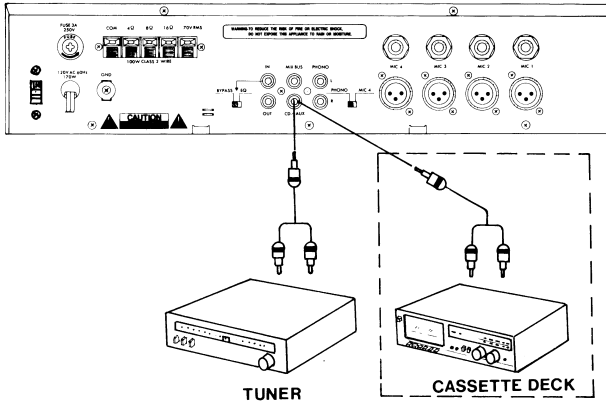

4. Connecting an Equalizer.

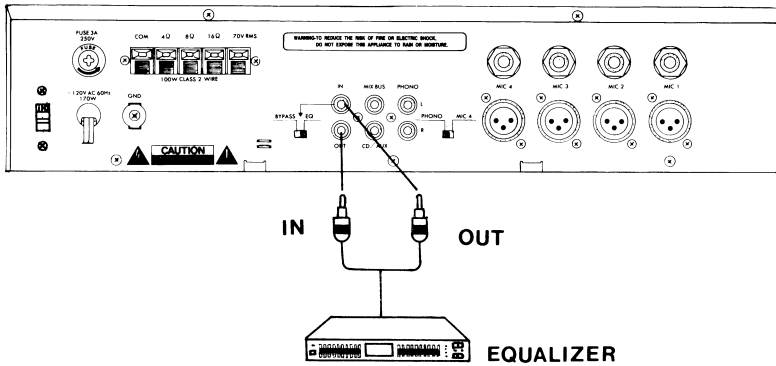

5. Connecting the MIX BUS Jack.

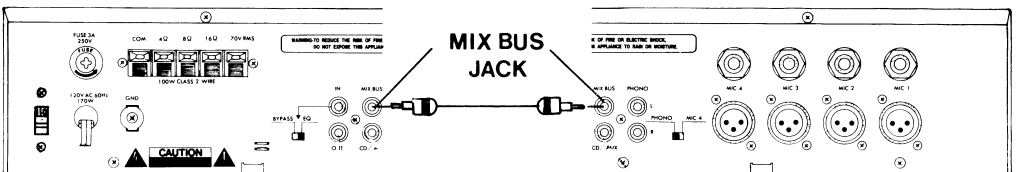

B. CONNECTING SPEAKERS

1. Connecting Only One Speaker.

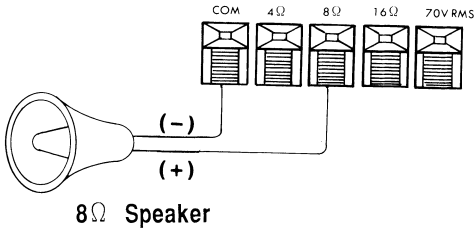

2. Connecting Two Speakers In Series.

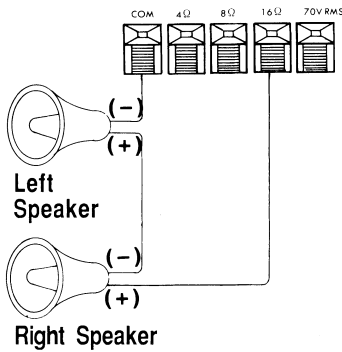

3. Connecting Two Speakers In Parallel

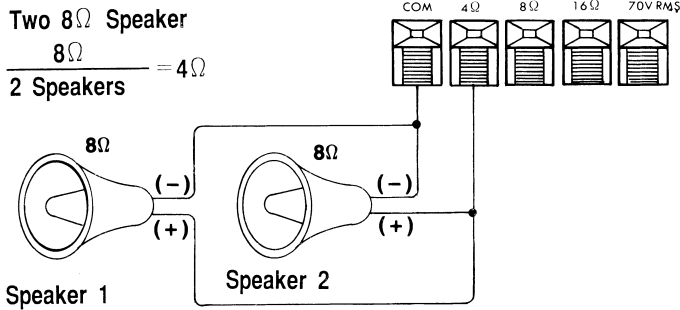

4. Connecting Four Speaker In Series/Parallel Combination.

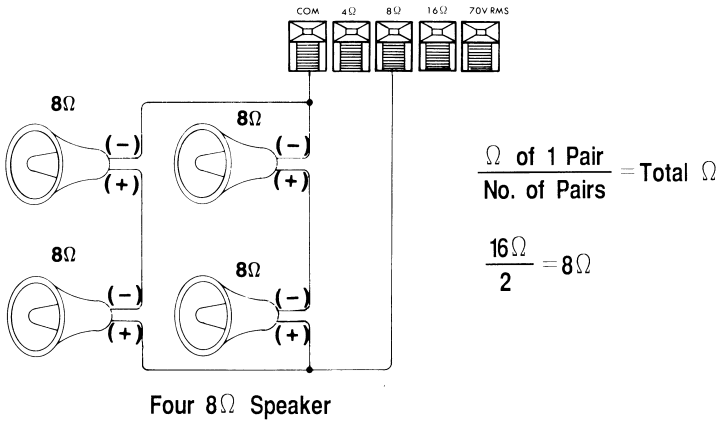

5 Connecting Speakers With Transformers.

Follow these steps to connect speakers with transformers.

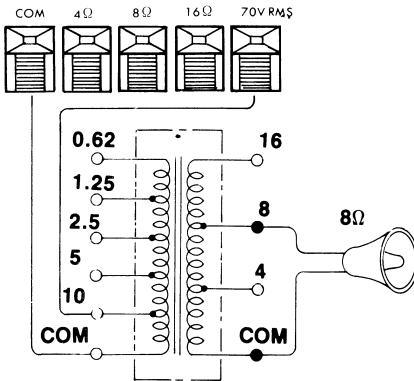

- 1 Connect a wire from the amplifier's **70V** terminal to the transformer's desired primary tap (10, 5, 2.5, 1.25 or 0.62 watts).

Note : Usually, each speaker in a system uses the same wattage tap. If you want a particular speaker to have a higher volume level, use a higher wattage tap on its transformer.

- 2 Connect a wire from the amplifier's **COM** (common) terminal to the C (common) tap on the transformer's primary side.
- 3 Connect a wire from the speaker's positive (+) terminal to the transformer's secondary tap the matches the speaker's total impedance (4Ω, 8Ω, or 16Ω).
- 4 Connect a wire from the speaker's negative (-) terminal to the C (common) tap on the transformer's secondary side.

SPECIFICATIONS

Output Power at THD 2%, 8 Ohm Load 1 kHz.	100W
Total Harmonic Distortion (at 70 Watts, 8 Ohms, 1 kHz, with Band Pass Filter)	
MIC (PHONE Jack).	0.25%
MIC (XLR Jack)	0.35%
AUX	0.20%
PHONO.	0.25%
Input Sensitivity (at 2% THD, 1 kHz)	
MIC (PHONE Jack).	1.35 mV
MIC (XLR Jack)	1 mV
AUX	150 mV
PHONO	2.8 mV
Signal to Noise Ratio (Input Shorted) with WTD	
MIC (PHONE Jack).	60 dB
MIC (XLR Jack)	54 dB
AUX	73 dB
PHONO.	60 dB
Frequency Respones (at 1 watt, \pm 3 dB)	
MIC (PHONE Jack).	60 Hz – 20kHz
MIC (XLR Jack)	75 Hz – 20kHz
AUX	60 Hz – 25kHz
PHONO (RIAA 100 Hz/10 kHz).	+ 12 dB/ – 12.5dB
Notch filter Effect	
RANGE.	300 Hz – 3 kHz
DEPTH.	– 12 dB
Hum and Noise with 30 kHz Low Pass Filter at 8 Ohms	
At MASTER VOLUME MIN	0.75 mV
At MASTER VOLUME MAX, Other MIN	6 mV
Power Requirements	AC 115V/230V Switchable
Dimensions	4 ³ / ₁₆ × 18 ¹⁵ / ₁₆ × 11 ¹⁵ / ₁₆ Inches (HWD)
	(10.0 × 48.0 × 27.3 cm)

Cautions:

- Before you connect the speakers, be sure the total wattage of the primary tap you intend to use does not exceed the amplifier's maximum 100-watt output power rating.
- Avoid multiple connections to the amplifier's 70V and COM terminals.